

UltiMaker playbook

# 3D printing functional metal parts



# Contents

Demand for small volumes of custom metal parts	3
The Metal FFF process	4
The anatomy of cost-effective metal 3D prints	5
Which new features does MFFF unlock?	6
Is it really a metal part?	7
Can it look like a metal part?	8
What do you need to produce metal parts?	10
Case study: Custom spray paint adaptors	12
Return on investment (ROI)	15
Summary	17

# Demand for small volumes of custom metal parts

At first glance, the barrier to entry for metal 3D printing seems high. Initial capital expenditure for the equipment. The required infrastructure. The technologies' associated hazards. The steep learning curve involved.

These factors and more have turned away many potential users who could have benefited from metal additive manufacturing.

But dig deeper and you will find an accessible, lower-cost route: Metal Fused Filament Fabrication (MFFF). This technology uses a desktop 3D printer, together with proven post-processing techniques to produce metal parts.

Compared to other metal 3D printing options, MFFF has a very low cost of entry (just over \$1,000 if you already have a compatible desktop printer). Plus, it comes with no significant health and safety considerations, while providing a high-value return. This is possible by creating low-volume parts at a 90% lower cost than CNC machining with similar or shorter lead times.

Users successfully adopting MFFF have found it to be a complementary, additional technology to the existing range of metal fabrication options. In particular, MFFF allows users to produce small volumes of custom parts where design complexity carries no additional cost.

And it's when comparing feature complexity and preparation efforts vs. volumes and material waste that MFFF really begins to shine.



# The Metal FFF process

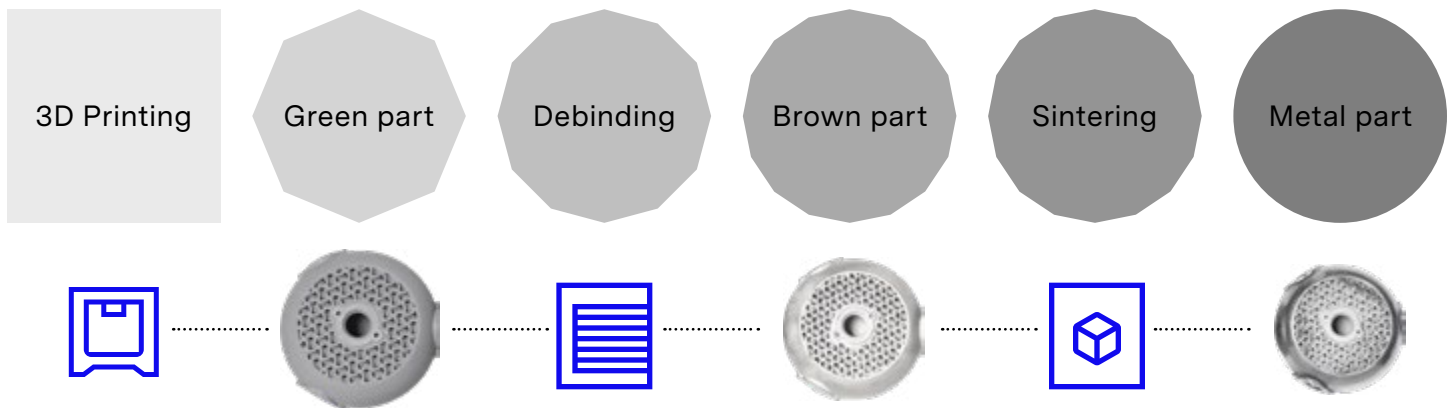

Figure 1: The Metal FFF process

## Step 1: Green part printing

Metal FFF uses a process similar to its thermoplastic counterpart. Highly charged thermoplastic filaments with more than 90% weight of metal powders are extruded via a heated print head in the XYZ directions

to create a 3D object, called the green part. This presence of thermoplastic binders is necessary to make the stainless-steel powders flowable and accessible for extrusion-based processes.

## Step 2: Debinding

The second step consists of debinding the printed green parts and stripping out most of the thermoplastic binder. About 80% of these organic materials are removed. And the result is a brown part ready for sintering.

## Step 3: Sintering

During the sintering step, the last organic materials present in the brown part are completely removed during a short thermal debinding step. The remaining stainless-steel powder is then heated to over 1,300 °C and the powder begins to solidify by various diffusion processes. The result is volumetric contraction and a clean, DIN / ISO-quality metal part.

# The anatomy of cost-effective metal 3D prints

When most people think of metal 3D printing, high-performance applications come to mind. Technologies, like Direct Energy Deposition (DED) and Powder Bed Fusion (PBF), these end-use parts achieve extremely tight tolerances, high density levels, and large part formats – in a wide range of metal grades. These capabilities are needed to justify the high cost of sourcing and operating these machines.

MFFF has a different sweet spot. An UltiMaker S series printer is best suited for metal applications where the volume requirements are low (1 to 20 per year). This intersection of flexibility and affordability is where MFFF can be of the most value.

These components include:

- Custom auxiliary components (i.e. NOT off the shelf)
- Small, functional prototypes
- Customized tools and fixtures
- Small series of slow-moving, high-MOQ (minimum order requirement) parts
- Plastic replacements in high-load and/or temperature-resistance environments

Within this category of applications, there are process-related limitations that need to be taken into account to guarantee a high-quality final part. Here are the most important design principles to keep in mind when selecting existing applications or designing new ones:

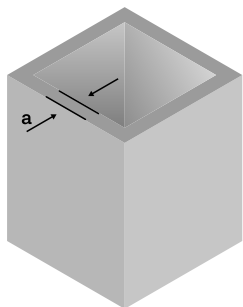

## Thin features

Thin features should be a multiple of the nozzle diameter. Where  $a$  in the diagram equals nozzle diameter,  $n$  should be a whole number

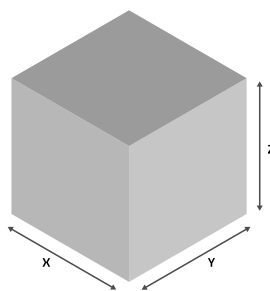

## Maximum part size

Parts should be no larger than 100 x 100 x 100 mm

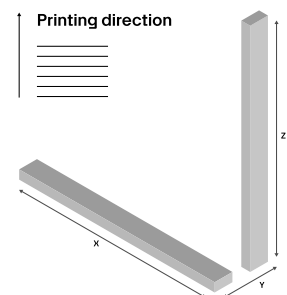

## Part orientation

Parts shrink the most in the Z direction, regardless of D&S orientation

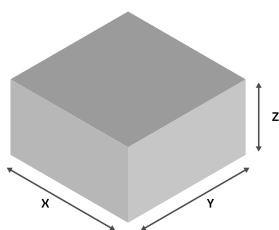

## Maximum wall thickness

The wall thickness should not exceed 30 mm

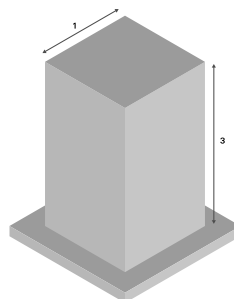

## Height to width ratio

A ratio no larger than 3:1 prevents collapse and distortion

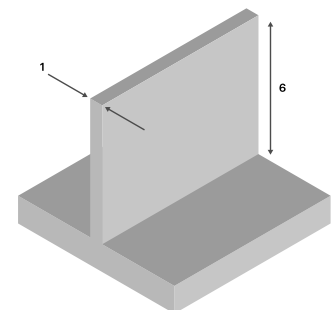

## Unsupported walls

For unsupported walls, a height-to-width ratio of 6:1 prevents collapse

Figure 2: Six key guidelines for printing metal parts with MFFF

# Which new features does MFFF unlock?

CNC will always remain a leading technology for creating prototypes of metal and plastic parts. MFFF is not here to substitute CNC or other traditional manufacturing technologies.

MFFF, however, can play a role as a complementary technology to CNC when it comes to small volumes of complex, customized parts that have features more suitable to be being created additively. This is true for complex features that require a high amount of preparation effort on a multi-axis CNC machine. And especially true when order volumes and material waste are considered.

Indeed, compared to CNC milling and DMLS, MFFF can bring additional design freedom and functionalities at no additional cost, such as:

- Interlocked assemblies
- Organic shapes via generative design
- Embedded features (e.g. cooling channels)
- Functional surface textures (e.g. fuzzy skin)
- High surface area geometries

And compared to powder bed fusion technologies, MFFF can also create closed hollow structures – particularly useful for making parts more lightweight.



Interlocked assemblies



Closed hollow structures



Organic shapes



Embedded cooling channels



Functional surface texture



High surface areas

# Is it really a metal part?

Steel parts printed with the UltiMaker Metal Expansion Kit and BASF Forward AM Ultrafuse® 17-4 PH. Followed by debinding and sintering through the network of D&S services or certified D&S ovens, like Fusion Factory from Xerion, offer the desired martensitic-like properties that the 17-4 PH grade is known for.

The excellent mechanical properties and good corrosion resistance make it one of the most popular and versatile metal materials on the additive manufacturing market.

At a glance, after sintering, parts feature similar characteristic to traditionally manufactured parts, such as:

- 17-4 PH grade stainless steel – martensitic-like elemental composition after sintering
- > 96% density
- Above 80% of mechanical properties of traditional CNC milled parts
- 17-4 PH printed parts can achieve better mechanical properties through heat treatment (up to 1.1 GPa ultimate tensile strength after precipitation hardening)
- Ideal for applications that need the highest possible mechanical properties and medium-high corrosion resistance

Table 1: Reported properties of 17-4 PH samples produced via MFFF, MIM, and CNC

	MFFF <sup>1</sup> (XY)	MFFF <sup>2</sup> (XY/ZX)   H900	MIM <sup>3</sup>	CNC <sup>4</sup>
Ultimate Tensile Strength (MPa)	760	990/1004   1276/1319	790	896 - 990
Yield strength Rp 0.2 (MPa)	680	756/764   1109/1136	650	827 - 914
Elongation at break (%)	4	3.8–4.0   6.4-7.0	4	6 - 6.97
Young's modulus (GPa)	190-195	190-195   197-202	190-200	197 - 207
Hardness (HV10)	257	291   426		250 - 260
Carbon concentration (%)	<0.03	<0.03	<0.03	<0.03
Average density	>96% of Bulk	>96% of Bulk	98.08%	99.99%
DIN ISO <sup>5</sup>	Stainless Steel 17-4 PH	Stainless Steel 17-4 PH	Stainless Steel 17-4 PH	Stainless Steel 17-4 PH

1 MFFF: Ultrafuse® 17-4PH TDS (Numbers refer to printed dogbones)

2 MFFF: Ultrafuse®17-4PH TDS (Numbers refer to printed, cut samples. Hardening according to H900 heat treatment method)

3 MIM: Metal Injection Molding – Metal Powder Industries Federation 35 min, 2018

4 CNC: Hubs

5 Stainless Steel 17-4 PH | 1.4542 | X5CrNiCuNb16-4

# Can it look like a metal part?

Many applications do not necessarily need post-processing. However, for those that require smooth surfaces and an appealing touch and feel, there are some easy and accessible methods to improve the visual quality of Metal FFF printed parts. For example, after printing, green parts are still relatively soft. Gentle sanding of flat surfaces can be done with **sandpaper**, while a detail razor can be used to clean up edges.

Otherwise, **sandblasting** using walnut shells or fine sand grades can also be used to smoothen the surface of more complex geometries which would be difficult to access just with sandpaper. Green sanded parts typically show a much finer surface finish than unsanded parts as you can see in the images below.

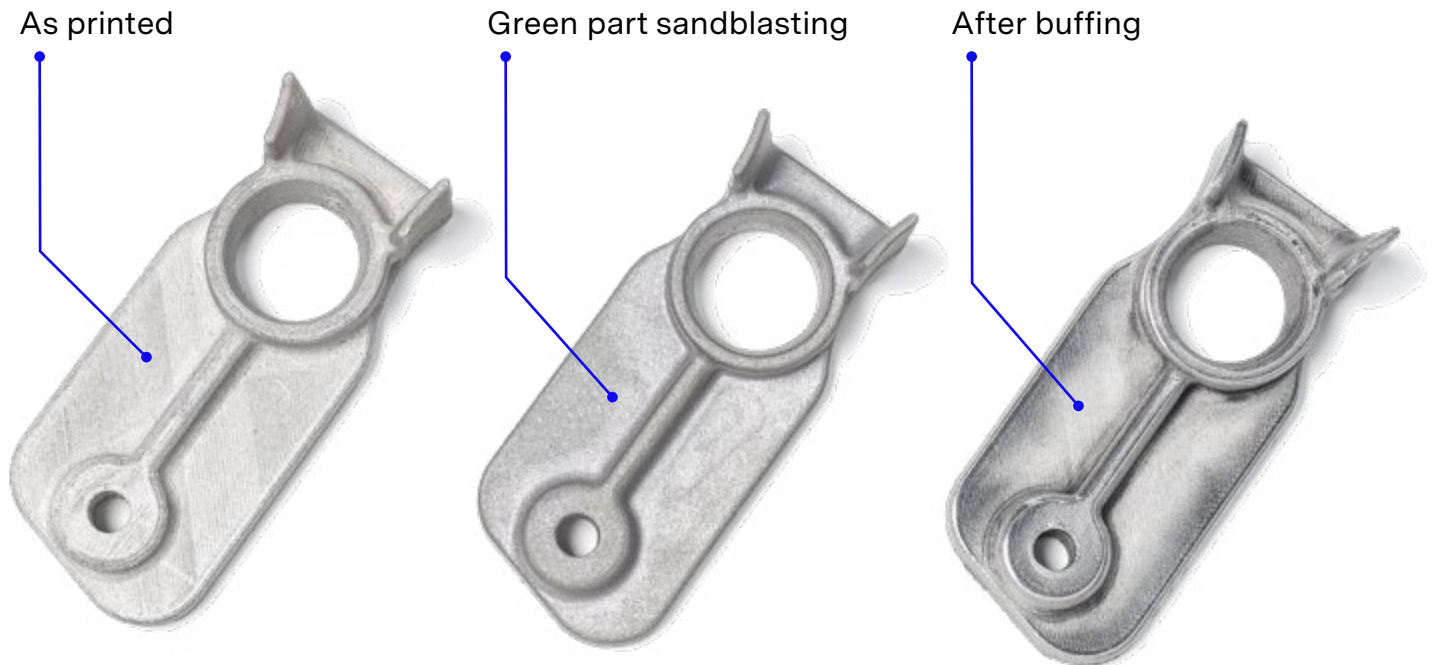

Figure 3: Results of different surface finishing for Liebherr Components' assembly tool





Figure 4: Before (top) and after (bottom) buffing post-processing

Despite the gains in surface smoothness achieved by sandblasting the green part, only a matte finish can be obtained after sintering. For a mirror finish, it's necessary to perform a buffing step on the sintered part. Applying a gentle abrasive to a work wheel can remove the rough and uneven surface layers, resulting in a brighter and smoother finish.

# What do you need to produce metal parts?

Users can now explore a new range of metal 3D printing applications by upgrading UltiMaker S series printers with the UltiMaker Metal Expansion Kit. This brings a simpler workflow and makes creating stainless-steel parts easier, more efficient, and more affordable.

Here is everything you need to successfully produce metal parts on the UltiMaker Platform:

- S series printer with an Air Manager
- Metal Expansion Kit, which includes:
  - BASF Forward AM Ultrafuse® metal filament, print cores, and other accessories
  - Exclusive access to metal 3D printing courses on UltiMaker Academy
  - UltiMaker Cura 5.1 or higher
  - Firmware 7.0.4 or higher
  - The latest Ultrafuse® 17-4 PH print profiles from the UltiMaker Marketplace

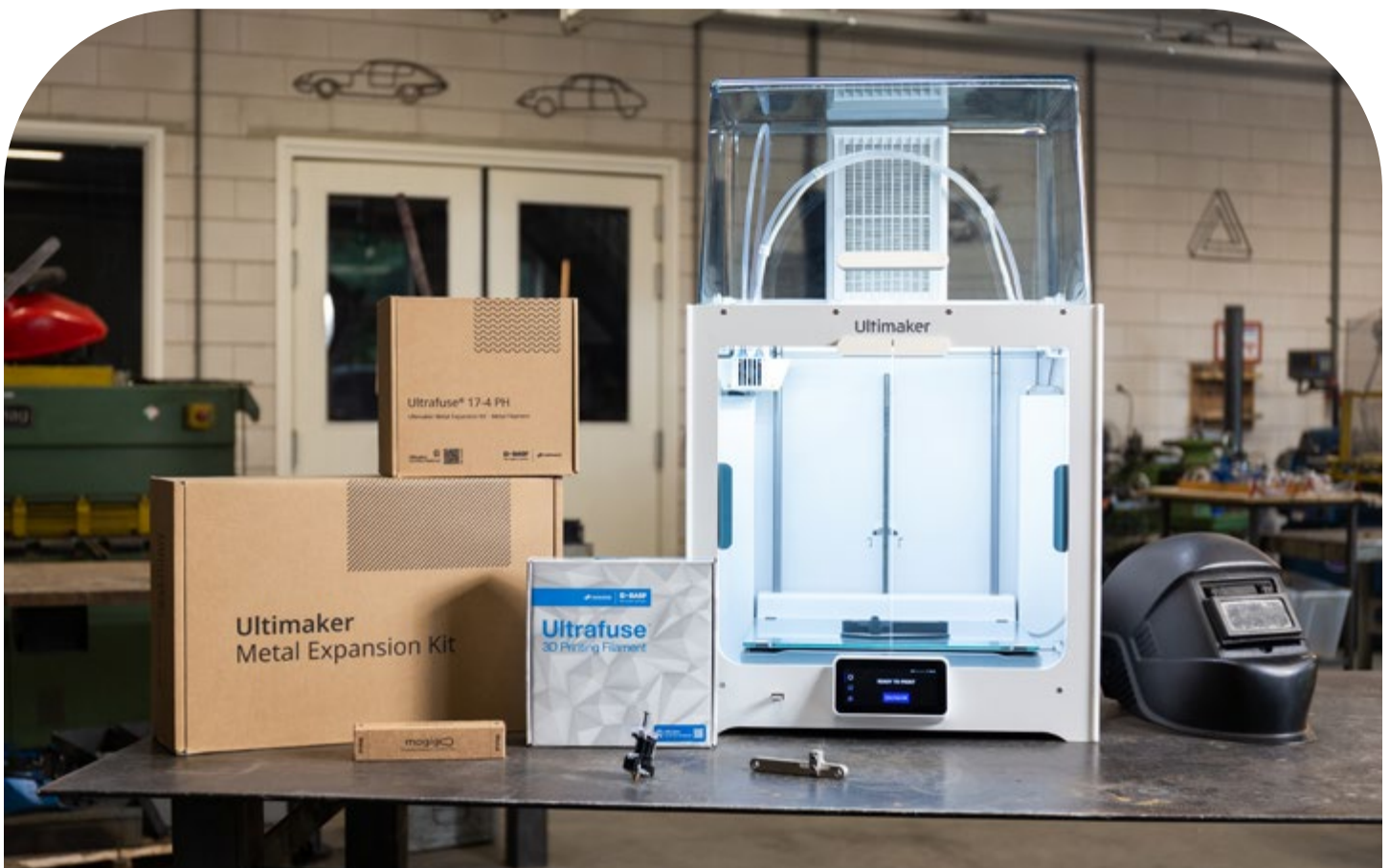

Figure 5: The UltiMaker Metal Expansion Kit items (left) and UltiMaker S5 printer with Air Manager (right)

Of course, post-processing steps are still needed to fully transform the 3D printed part into a finished metal part. For this, BASF Forward AM has developed a delocalized network of service partners who perform post-processing in an industrial-quality environment at the most competitive cost on the market.

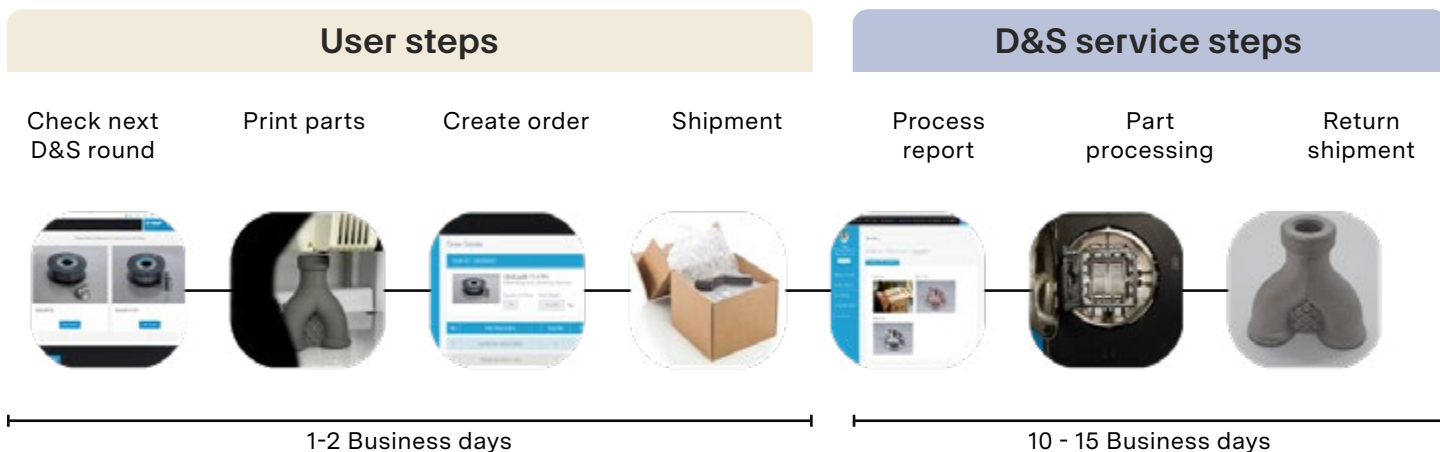

Figure 6: Steps to access the BASF Debinding and Sintering service network

Using this network is the most accessible way for users to insource part production. Doing so requires minimal investment (only an UltiMaker S series printer and the UltiMaker Metal Expansion Kit) to try the workflow. And then their parts are processed by experts with experience, professional equipment, and the most competitive price.

Today, access to the network has been further simplified thanks to our recently launched debinding and sintering order management portal. This allows customers to create a service order digitally and follow the operations and status of their parts live while they are being processed at the partner facility.

# Case study: Custom spray paint adaptors



Figure 7: Sintered spray paint adaptors

How does metal 3D printing using an UltiMaker S series printer compare in cost and lead time to other metal fabrication options?

Low volumes of this type of custom application can be 3x to 10x more expensive if produced by traditional milling machines or other 3D metal printing processes.

We found this by comparing the cost per unit and lead times to produce these custom spray paint flow adaptors across different technologies. We requested a series of quotes for 3 units in 17-4 PH from different external metal parts providers around the world.

At the same time, we began the process of producing the adaptors internally.

Measuring 47 x 31 x 31 mm, and weighing 75 grams, the components' size fits well within the limitation of UltiMaker MFFF. And no additional support material was needed to ensure part stability during the debinding and sintering steps.

As the table shows below, parts produced in-house using the UltiMaker Metal Expansion Kit offered a unit price 62% lower than the next best alternative (MFFF carried by the service bureau, Sculpteo).

Compared to other manufacturing technologies, in-house production yielded cost savings of 85% when compared to the cheapest CNC workshop offer. And up to 95% when compared to the same parts produced by DMLS at Protolabs. Interestingly, lead times with in-house production remain in line with the current estimated lead time from both online workshops and local ones.

	Service provider	Country	Technology used	Unit price	Total price	Part lead time	Quote lead time	Total costs <sup>1</sup>	MFFF savings <sup>2</sup>
1	In-house	Netherlands	MFFF	€ 28	€ 85	15 days	-	-	-
2	Sculpteo	Online	MFFF	€ 43	€ 128	17 days	-	+ € 44	34%
3	Protolabs	Online	DMLS	€ 116	€ 346	15 days	-	+ € 261	75%
4	Protolabs	Online	CNC	€ 541	€ 1,153	21 days	-	+ € 1,068	93%
5	Xometry	Online	DMLS	€ 172	€ 513	19 days	-	+ € 428	83%
6	Xometry	Online	CNC	€ 163	€ 487	27 days	-	+ € 402	83%
7	3D Hubs	Online	CNC	€ 181	€ 181	23 days	-	+ € 96	53%
8	Workshop	Germany	CNC	€ 99	€ 297	20-25 days	2 days	+ € 212	71%
9	Workshop	US	CNC	€ 200	€ 600	20 days	2 days	+ \$ 515	86%
10	Workshop	Netherlands	CNC	€ 316	€ 948	20 days	6 days	+ € 863	91%

■ With UltiMaker Metal Expansion Kit    ■ Via service bureaus

Option 1: Including material cost of €129 per kg, shipment to D&S (4.5 EUR/USD), 50 EUR/USD D&S voucher (1 kg)

1 Total cost vs option 1 - In-house MFFF 3D printing

2 MFFF Savings (%) vs other options

Please note: UltiMaker cannot guarantee the accuracy of third-party service provider data (options 2-10). The data is based on (i) information known at the time the data was created and (ii) the experience of UltiMaker. UltiMaker strongly recommends you obtain quotes prior to a purchase decision.

To fully assess the surface quality of the MFFF printed and sintered spray adaptor using the UltiMaker S5 and the UltiMaker Metal Expansion Kit, we performed a high-resolution scan analysis for a selected number of printed parts on GOM ATOS Core 3D scanner.

Figure 8 shows a color-map surface comparison between the CAD file and the cloud points' data resulting from the scanning of the object. This highlights the relative deviations between the ideal model (CAD) and the actual scanned part (cloud points obtained from scanning the physical item). The two sets of data have aligned one relative to the other by minimizing the overall sum of the squared distance of each pair of points (minimum quadratic error).

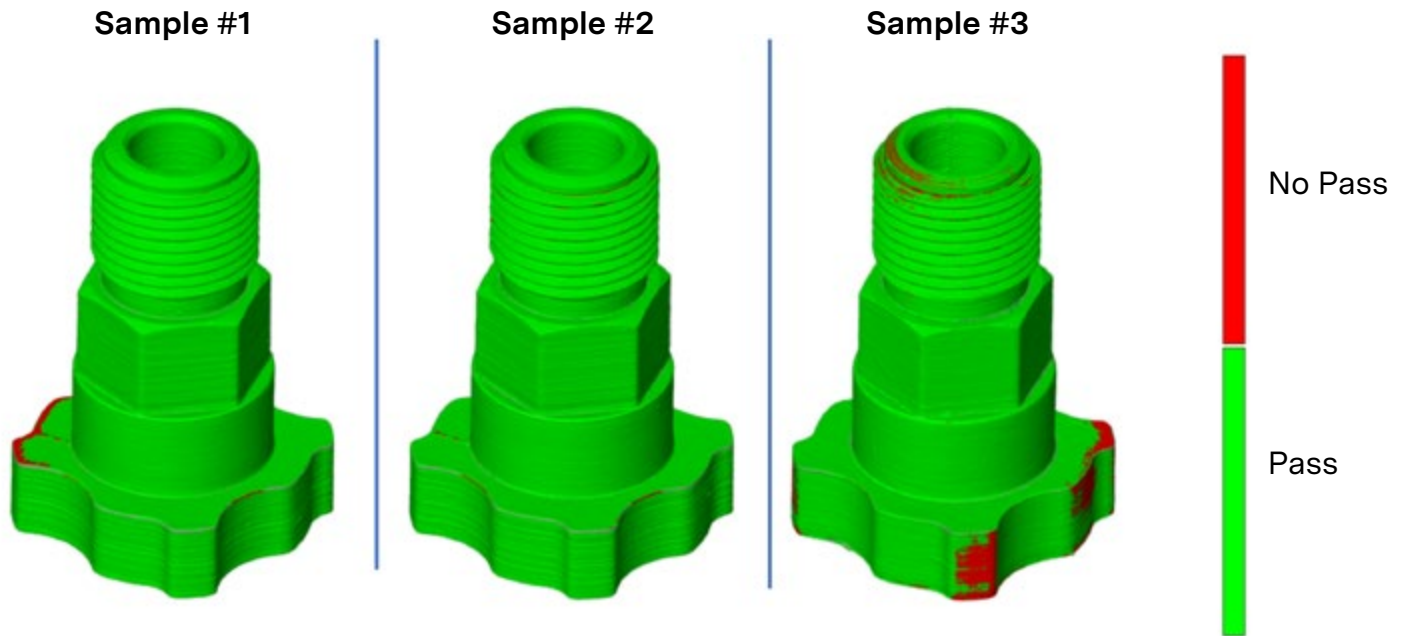

Figure 8: Color map generated through a pass/no pass filter with a threshold of  $\pm 0.3\text{mm}$  for the 3 adaptors printed and sintered

The color map generated through a pass/no pass filter with a threshold of  $\pm 0.3\text{mm}$  is shown in Figure 8. To visually correlate colors with surface points' deviations, green and yellow were chosen to indicate points still laying within the assigned threshold, whereas red points on the surface do not.

From the generated color map in Figure 8, it is possible to see that more than 99% of the points for sample 1 and 2, and more than 95% of the surface of the scanned sample 3, fall within the tolerance range of  $\pm 0.3\text{ mm}$ . As for the out-of-tolerance area (red) present at the base of the object, this does not impact its usability given this area's lower relevance within the working adaptor assembly.

# Return on investment (ROI)

MFFF is not only a competitive solution compared to the cost of other metal manufacturing solutions. It also achieves a fast ROI.

This is because it uses a desktop 3D printer together with well-proven post-processing techniques to produce metal parts. It comes with a very low cost of entry (just over €1,000) if you already have a compatible 3D printer, like the UltiMaker S5. And it can provide a high-value return by creating low-volume parts at a much lower cost than CNC machining.

Initial investment*		Metal Printing		Plastic Printing	
UltiMaker S5	€ 6,350	Avg. Annual metal consumption year	20%	Avg. Annual metal consumption year	80%
UltiMaker Air Manager	€ 750	Total annual consumption	5 kg/year	Total annual consumption	20 kg/year
UltiMaker Metal Expansion Kit	€ 1,199	EUR/kg printed and sintered parts	€ 180	EUR/kg printed and sintered parts	€ 60
		Total annual material cost	€ 720	Total annual material cost	€ 1,200
		Avg. Savings / part	65%	Avg. Savings / part	65%

\*Please note: All prices exclude tax, are accurate at the time of publication, and are subject to change

The savings above do not include inventory stock gains, purchase order time, lead-time gain, or indirect benefits on system maintenance and lifetime.

Thanks to the low total cost of ownership and average savings per part of 65%, early adopters of the UltiMaker Metal Expansion Kit with the UltiMaker S5 are already realizing a return on investment (ROI) of less than 2 years.

Such a short ROI period also originates from the fact that users don't need to purchase an additional dedicated printer exclusively to produce metal parts. Instead, they can switch freely from plastic printing to metal printing and back without any permanent modification to the printer.

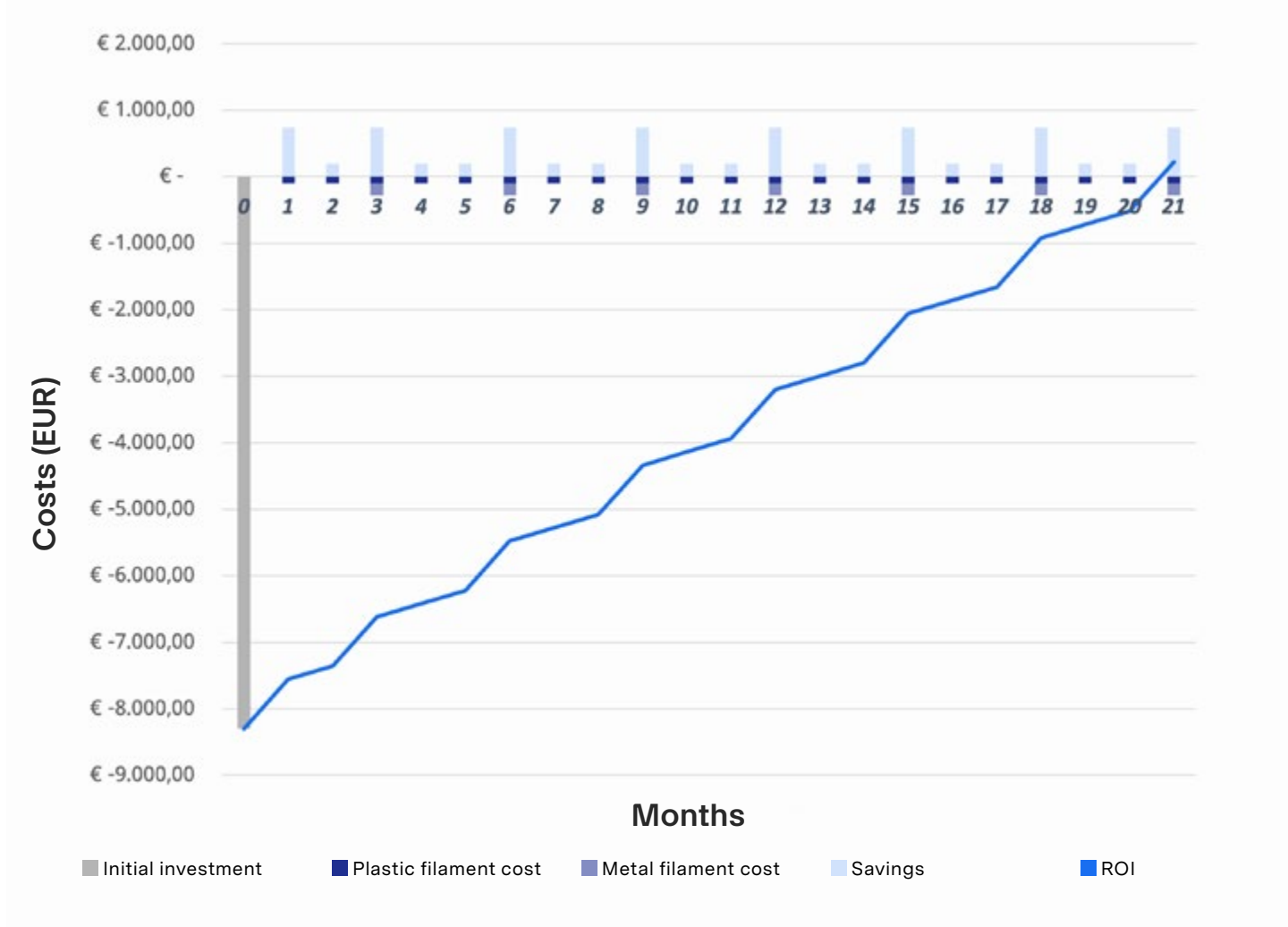

Figure 9: Return over investment plot using assumptions listed in Table 3. Insert: Return over investment for UltiMaker Metal expansion kit only

As shown in Figure 9, return over investment can be achieved within a few kilograms of successfully sintered parts once users already have the correctly configured hardware setup. In this case, the initial investment is so low that, after 2 kg of printed parts, savings exceed the investment needed to upgrade an UltiMaker S series printer with the UltiMaker Metal Expansion Kit.



# Summary

As you have seen in this white paper, 3D printing steel parts on an UltiMaker S series printer using the UltiMaker Metal Expansion Kit enables:

- Tolerances <  $\pm 0.4$  mm
- A clear application sweet spot
- A low total cost of ownership (under €10,000)
- ROI in less than 2 years
- Cost savings per part from 60% to 95% cost (at competitive lead-time) within the application sweet spot
- 6 additional features made possible with MFFF (vs CNC and DMLS)
- A real metal part inside and out, including
  - Typical 17-4 PH martensitic-like crystalline structure and properties
  - Mirror-like touch and feel possible with sand blasting and buffing

## Ready to upgrade to metal 3D printing?

**Discover more metal applications**

**Buy the UltiMaker Metal Expansion Kit**

# Reliable 3D printers that simply work for you

Discover the UltiMaker 3D printers that will streamline your workflow and deliver the quality results you need.



## What does our unique platform include?



Workhorse 3D printers that achieve fast ROI



Click and print with over 240 materials



Secure cloud software for easy remote printing



Global access to expert support and learning

Learn more at [ultimaker.com](https://ultimaker.com)