

you can  
**Canon**

Large Format  
Print Solutions

LFP SOLUTIONS



Photography & Fine Art

*We Speak Image*

Expand the realms of possibility and help your masterpieces spring to life in digital with **Canon's Large Format Printers for Photography and Fine Art applications.**

The expanding world of Large Format photography and digital Fine Art has never been better served than now. Canon's extensive range of specialist Large Format devices and media provides everything you need for today's outstanding productions and tomorrow's gallery showpieces.

**Big benefits with Canon**

Since we developed the first camera back in 1934, Canon have been at the forefront of digital image capture. Today, our digital SLRs are the first choice for many photography professionals. Creating large-scale digital fine art or photography requires considerable skill, so it's important to back it up with the technology that will ensure your work is seen in the best possible light. Our heritage and reputation in photography and ink jet printing results in a range of Large Format Printers that deliver in all areas. Outstanding image expressiveness and exceptional colour reproduction come courtesy of our 12-colour LUCIA pigment ink system. And Canon's FINE technology and L-COA system architecture ensure your finest creations are delivered at exceptional speeds.

**Create and produce everything you desire.**

## Canon's Large Format Print Solutions for **Photography & Fine Art**



iPF5100



iPF6100



iPF8100



iPF9100

### The range

Canon's range of Large Format Printers for Photography and Fine Art give you the confidence to deliver your best work every time. The 12 colour LUCIA ink system delivers exceptionally accurate colours by including both RGB and CMYK inks. This innovative system proves incredibly cost effective too as there's less of a need to blend colours to produce the results you desire, ensuring a sound return on your investment.

You'll find a comprehensive range encompassing 4 specialist devices – spanning A2 (17") up to 60" printing – that are incredibly easy to work with, leaving you to focus all your attentions on those masterpieces in the making.



**imagePROGRAF**

The finest results for:

- **Professional Photographers and studios**
- **Digital Fine Artists and Fine Art Productions specialists**
- **General Print Service Providers**

Canon's Large Format Print Solutions for Photography and Fine art



## The wider your imagination, the bigger the possibilities

Imagine extending your photographic services portfolio with stunning large format production capabilities. Or finally being able to experience your finest art creations as centrepieces in the galleries that matter. We can help you make it happen.

### Exceptional colour reproduction

The extra special results that your work demands is delivered with Canon's incredible 12-colour LUCIA pigment ink system. The full spectrum of colours is produced with unnerving accuracy and perfect balance due to the inclusion of dual RGB and CMY inks. A dual print head featuring 30,720 nozzles produces super-fine, evenly distributed 4 picolitre ink droplets.

### Brilliant black and white photography

Capture those classic black and white shots with the benefit of high quality large format production values. A combination of black, matt black, grey and photo grey inks allow for incredibly lifelike photography with exceptional detail, opening the door to numerous applications such as wedding photography, christenings, and the fast growing lifestyle portrait work.

### Results that last forever

Prints are highly scratch resistant and unaffected by lighting variations, providing outstandingly consistent results for around 100 years.

### Super quick performance

Using the highest quality 12-colour ink system doesn't mean you have to compromise productivity. Each printer is capable of extraordinary speeds. The iPF9100 can print A0 draft prints in just over 2 minutes whilst the iPF5100 can print A2 in just 41 seconds.



### Easy to use

Device operation is simple thanks to a large LCD panel which provides clear menu-driven controls for all functions. Various types of media are handled giving you added flexibility for your artistic creations and photography. Potential media misalignment is virtually eradicated thanks to auto-skew correction which automatically adjusts for any skew in orientation and feeds the paper correctly. Plus, a thoughtfully designed fan system ensures the quietest of operation, ensuring your device is a pleasure to work with.

### Truly cost effective

The 12-colour LUCIA ink system also enables printing that's particularly economical. There is less need to blend colours (such as magenta and yellow to create red), so less ink is required. Two grey inks are also included, further reducing the need to blend colours and keeping costs down.

As you would expect from Canon, reliable performance is a given and for added peace of mind, our print heads feature a 12-month warranty.



# The finest innovations create a huge impact

Wherever your imagination takes you, we want you to be free to experience it with Canon. That's why we've invested heavily in research and development to produce a specialist Photography and Fine Art Range that fulfils your highest aspirations.



## Print with FINE technology

To deliver faithful image expression, ink droplets must be extremely small and precisely distributed. When droplets become microscopic however, image quality is affected by problems such as uneven droplet size and placement on the paper. Conventional printing systems compensate by making multiple passes for each line but this adds significantly to print times.

Canon's FINE (Full photolithograph Inkjet Nozzle Engineering) overcomes this problem without needing to make multiple passes, producing bi-directional printing at incredible speeds. An innovative ink-nozzle manufacturing method results in precisely uniform droplets and outstanding photo-quality print performance.



## Canon's LUCIA 12 colour ink system

### CMY and RGB LUCIA inks

Canon's incredible new LUCIA 12-colour ink system sets the standard in high quality, expressive colour reproduction. As well as conventional CMY (cyan, magenta, yellow) inks, RGB (red, green, blue) inks are incorporated. Since these two systems have a complementary colour relationship, they enable superb, distortion-free, balanced colours over the entire and expansive colour space.

### Grey and Photo Grey

The 12-colour system includes grey and photo grey, enabling constant monochrome prints with smooth graduations and virtually no graininess compared to conventional printing technologies.

### Black and matt black

Two types of black ink help produce optimum results. For photo-type media, a black ink (BK) is used and for high contrast prints on matt paper, a matt black (MBK) is used. This process ensures smooth graduations across all media and is highly efficient, as the relevant ink is automatically selected for each media type.

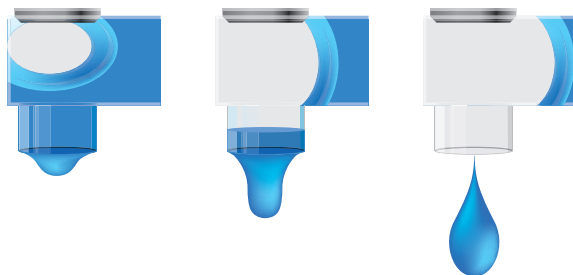

Canon's FINE technology uses ink bubbles that are formed at the top of the nozzle to separate and eject the ink.



Innovative technology  
that breaks new  
boundaries.



### L-COA for unbeatable productivity

Providing the optimal balance between high productivity and high quality is Canon's Large Format Printer Common Architecture (L-COA). L-COA helps your printer carry out the most complex print jobs with ease.



### Colour management with KYUANOS

A next generation colour management system is featured in the imagePROGRAF printer driver and in the optional PosterArtist 2007 software. KYUANOS helps ensure optimal results for media that's to be used across varying light conditions. This enables you to compensate for colours before printing, depending on the viewing environment, to ensure optimum colour reproduction in the finished prints.

### Advanced Colour Calibration

A powerful colour calibration system ensures the most stable colour reproduction attainable. In conventional systems, changing the print heads may cause a minute variation in print output, due to the density characteristics of the print head. With Canon's Advanced Colour Calibration, a multi-sensor measures variations in density on a printed calibration chart and then automatically applies any appropriate adjustment to ensure an exact match for long-term consistency.

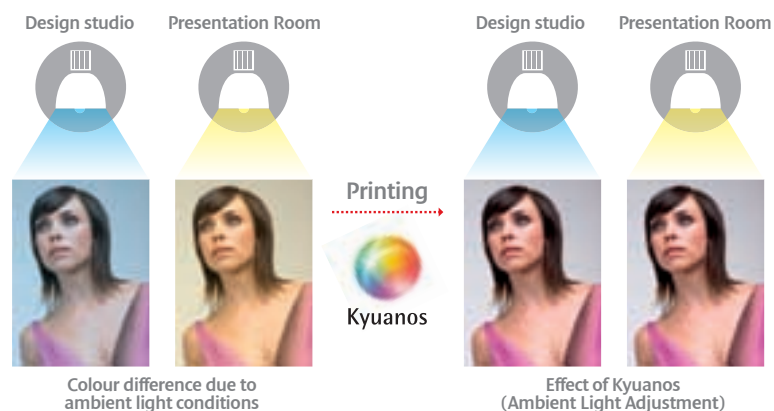

# A wide range provides everything you need

With four specialist devices, Canon's Photography & Fine Art Printer Range offers the flexibility of choice you need to bring all your most ambitious ideas to life.

## Overview

### iPF9100

**12 colour LUCIA pigment ink system** for outstanding image expression and superb colour reproduction

**Reduced graininess** with optimum results across all media types

**Fast production** capabilities with speeds of up to 31.9 sqm/hr

**Borderless printing** up to 42" in size

**Auto Skew Correction** for trouble-free printing

**'Hot Swap' ink tanks** for continuous production (iPF8100 and iPF9100)

**Powerful software** to help with your creations

**80GB HDD** as standard

**Large LCD control panel** makes operation quick and simple with fast error recovery

**Cost efficient printing** with 12 colours due to less colour blending



iPF5100



iPF6100



iPF8100





## Canon Media & Ink

### Media matters

More choice and better quality for you and your customers comes courtesy of Canon's exclusive range of specialist media. Designed for Large Format Printing applications we offer 40 high quality specialist options for Proofing, CAD&GIS, Photography & Fine Art and Production sectors.

Using Canon media ensures your creations are produced with products designed to work in harmony for the highest possible performance levels. The entire Canon media range is also supported with ICC profiles and preset printer settings for quick, predictable and trouble-free operation.

For Fine Art applications there are four specialist media including embossed paper and water resistant canvass. For Photography there are a further eleven including satins and glossy photo paper. A diversity of weights and roll widths are available giving maximum choice.

### Quality results with Canon inks

We're constantly looking to fine-tune the quality of our inks and thereby the quality of your prints. That's why we've developed the 12-colour LUCIA pigment ink system to give the best results in the applications you need them for. For Fine Art creations and Photography work you need the widest colour gamut and the most accurate and expressive colours, so make sure you choose Canon's LUCIA inks - specifically developed for this purpose.

The finest results  
with Canon Inks  
and Media.

#### Roll widths available

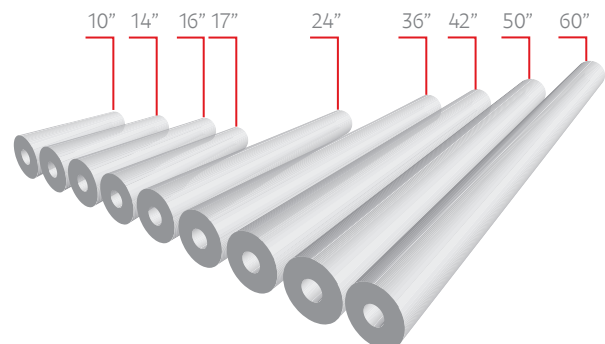

Canon's Large Format Print Solutions for Photography and Fine art



## Powerful software helps you think big

We work hard to understand how your business works. In doing so we're able to develop products that match your highest expectations and added value software that helps you explore your ambitions to the full.

### Effortless control

Ultimate control comes courtesy of Canon's flexible imagePROGRAF Printer Driver. An "easy mode" allows you to use Canon's pre-defined settings for speed and simplicity of use. Switch to "advanced mode" however and you can adjust drying times, colour settings and manage your own ICC profiles.

### Effortless control

Page set-up provides pure flexibility allowing customised page sizes if required and a best-fit option for each media is selectable. Select the watermark feature and you can protect the rights of your images. For enhanced workflow, pre-defined settings can be created using hot folders.

A maintenance facility allows you to adjust the media feed, do a nozzle check, clean the print heads, check the queue and carry out other timesaving procedures.

### Digital Photo Front Access

This useful application allows you to import digital photos from your digital camera. Intuitive software allows you to easily edit photos before printing and also enables you to link with other applications such as Adobe Photoshop and Canon PosterArtist.





Expand your possibilities.

### Plug-In for Digital Photo Professional

Artists and professional photographers benefit from direct links to Canon's Digital Photo Professional software which is included with our range of digital cameras.

### Plug-In for Photoshop

Canon Photoshop Plug-In automatically converts 16-bit images in PhotoShop to 12-bit images to be used by your Large Format Printer. Normally, PhotoShop sends a print job to a printer in 8 bit (since OS doesn't support 16 bit when using the printer driver), and consequently the optimum quality will not be achieved. With this useful feature you ensure optimum quality at 12-bit.

### Create incredible posters

It's also possible to use your printer for entirely different means. Opt for Canon's PosterArtist 2007 software and you can use it to create incredible borderless posters, signs and displays.

LARGE FORMAT PRINT SOLUTIONS

Explore huge possibilities with Canon.



tel: 0871 222 2816  
email: [info@plot-it.co.uk](mailto:info@plot-it.co.uk)  
[www.plot-it.co.uk](http://www.plot-it.co.uk)



you can  
**Canon**

Canon Inc.  
[www.canon.com](http://www.canon.com)

Canon Europa N.V.  
[www.canon-europe.com](http://www.canon-europe.com)

English UK Edition 0119W396 -  
5026173425186  
© Canon Europa NV 2008 (0208)

Canon (UK) Ltd  
Woodhatch, Reigate  
Surrey RH2 8BF  
Telephone No: 01737 220000  
Facsimile No: 01737 220022  
[www.canon.co.uk](http://www.canon.co.uk)

Canon Ireland  
Arena Road, Sandyford  
Industrial Estate  
Dublin 18, Ireland  
Telephone No: 01-2052400  
Facsimile No: 01-2958141  
[www.canon.ie](http://www.canon.ie)